

ANDREW YULE & CO. LTD. – KARBALLA TEA ESTATE
Construction of Single Unit Labour Latrine
Ref. Tender No.: WB/KA/2021-22/04

Scope of Work : Construction of Proposed Sanitary Latrine with S. Tank at Doars Tea estate in the Dist. of Jalpaiguri, W.B.

Location : Banarhat, Karballa & Choonabhutti T.E. – 11 Nos. at Each Garden (Approx.)
 Located at Banarhat Area, Dooars, West Bengal

Description of Work : Brick Masonary wall with GCI sheet roof over wooden truss including the fitting of M.S. door, Septic tank (As per Plan), Sanitary fittings complete . Details as follows :

Item No	PARTICULORS OF WORK	QTY .	UNIT
1)	Earth Work in excavation of foundation trenches or drains in all sorts of soil (including mixed soil but excluding latrite soil or sandstone) including removing, spreading or stacking the spoils with in a lead of 75 m as directed. The item includes necessary trimming the sides of trenches, levelling, dressing, and ramming the bottom, bailing out water as required complete . (a) Depth of excavation not exceeding 1.50 M As per IS Code - 1200 Pt. I-1992	3.50	Cu.M.
2)	Earth work in filling in foundation and trenches or plinth etc. in layers not exceeding 150 mm including watering and ramming etc. complete . (a) With earth obtained from excavation of foundation .	0.70	Cu.M.
	(b) with earth obtained by fresh excavation (including cost of excavation upto 1.80 m depth from land arranged by Deptt.) Within a lead of 100 m. For plinth filling -	2.80	Cu.M.
3)	Single B.F.S. of picked jhamma bricks including ramming and dressing bed to proper level and filling joints with powdered earth or local sand . As per IS Code - 1077-1992	3.60	Sq.M.
4)	Cement Concrete (1: 3: 6) with 40 mm down graded shingles excluding shuttering. As per IS Code - 456-2000	0.408	Cu. M.

5)	Ordinary Cement Concrete M 15 (mix 4: 2: 1) with 20 mm down graded stone chips / shingles excluding shuttering and reinforcement if any, in ground floor . (a) Crushers - As per IS Code - 456-2000	0.185	Cu. M.
Item No	PARTICULORS OF WORK	QTY .	UNIT
6)	Reinforcement for reinforced concrete work in the all sorts of structures including distribution bars, stirrups, binders etc. including supply of rods, initial streaghtening and removal of loose rust (if necessary), cutting to requisite length, hooking and bending to correct shape, placeing in proper position and binding with 16 gauge black annealed wire at every intersection, complete as per drawing and direction . (a) For works in foundation, basement and upto roof of ground floor / upto 4.0 m . (i) Tor Steel / Mild steel . @ 0.80 % of (C.C. work for M15) 0.185 Cu.M = As per IS Code - 432-1982	0.12	Quintel
7)	Brick work with 1 st class bricks in cement mortar (6 : 1) . (a) In foundation & plinth (b) In superstructure, ground floor As per IS Code - 2212-1991	0.563 0.281	Cu. M. Cu. M.
8)	125 mm thick brick work with 1st class bricks in cement mortar (4 : 1) in ground floor . As per IS Code - 2250-1981	15.20	Sq.M.
9)	Artificial stone in floor, dado, staircase etc. with cement concrete (4:2:1) with stone chips laid in panel as directed with topping made with ordinary or white cement (if necessary) and marble dust in propertion (2:1) including smooth finishingand rounding off corners and including application of cement slurry before flooring works using cement @ 1.75 Kg / Sq.M all complete including all materials and labour . 3 mm thick topping with ordinary cement (High polishing grinding on this item is not permitted) . (a) 20 mm thick - As per IS Code - 2571-1970	1.35	Sq.M.

Item No	PARTICULORS OF WORK	QTY .	UNIT
10)	<p>Supplying, fitting and fixing steel doors with or without integrated grills conforming to I.S. 7452 - 1973 with non friction projecting type hinges, glazing chips, lugs, locking plate, peg stays, 1.25 mm thick M.S. sheet welded kicking plates in double tray construction brass door handle with minimum 4 lever mortice lock openable with key both from inside and outside together with a locking bolt on the inside face including hoisting in position, straightening, if required fixing lugs in cement concrete (1:2:4) with stone chips 20 mm size cutting holes and mending good damages to match with existing surface complete in all respect including glazing .</p> <p>(b) Openable steel Door / windows - As per IS Code - 1038-1983</p>	1.800	Sq.M.
11)	<p>M.S. structural works in roof trusses with Tubular sections conforming to IS: 806 - 1957 & IS :1161-1958 connected to one another with bracket, gusset, cleats as per design, direction of Engineer In Charge complete including cutting to requisite size, fabrication with necessary metal are welding conforming to IS : 816 - 1956 & IS : 9595 using electrodes of approved make and brand conforming to IS : 814 - 1957, haulage, hoisting, and erection all complete . The rate includes the cost of rolled steel section, consumables such as electrodes, gas and hire charges of all tools and plants and labour required for the work including all incidental charges such as electricity charges, labour insurance charges etc</p> <p>(a) For trusses spanning upto 12.0 M</p>	0.080	Quintel
12)	<p>Galvanized corrugated iron sheet work (excluding the supporting frame work) fitted and fixed with 10 mm dia. J or L hook bolts, limpet and bitumen washers and putty complete with 150 mm end lap & one corrugation minimum side lap complete.</p> <p>(i) In roof (b) With 0.60 mm thick sheet As per IS Code - 277-2003</p>	4.680	Sq.M
13)	<p>Plaster (to wall, floor, ceiling etc.) with sand and cement mortar including rounding off or chamfering corners as directed and racking out joints or roughening of concrete surface including throading, nosing and drip course where necessary in G. floor .</p> <p>(i) With (6 : 1) cement mortar (b) 20 mm thick plaster</p> <p>(c) 15 mm thick plaster As per IS Code - 2250-1981</p>	12.00	Sq. M
		15.00	Sq. M

Item No	PARTICULORS OF WORK	QTY .	UNIT
14)	Neat cement punning about 1.50 mm thick in wall, Dado, window sills, floor, drain etc. Cement to be used 0.152 Cu.M per 100 Sq.M	2.00	Sq. M
15)	Red oxide wash of approved shade including cleaning and smoothening surface thoroughly (withot specific permission from the Engineer in charge this item of work must not be done on an old painted surface which has not received such red oxide wash before) . (b) One coat - As per IS Code - 102-1962	4.00	Sq.M.
16)	Painting with best quality synthetic enamel paint of approved make and brand including smoothening surface by sand papering etc. including using of approved putty etc. on the surface if necessary (b) On steel or metal surface (iv) Two coats (with any shade except white) As per IS Code - 13607 - 1992	4.00	Sq.M.
17)	White washing including cleaning and smoothening surface thoroughly (5 parts of stone lime and 1 part of shell lime should be used in the finishing coat) . (b) Two coats - As per IS Code - 6278-1971	25.00	Sq.M.
18)	Sanitary works for fitting Pan, Trap, pipe, gas pipe etc as complete	L. S.	L. S.

Note : All Materials should be of ISI standard.

DRAWING of Proposed Single Unit Labour Latrine

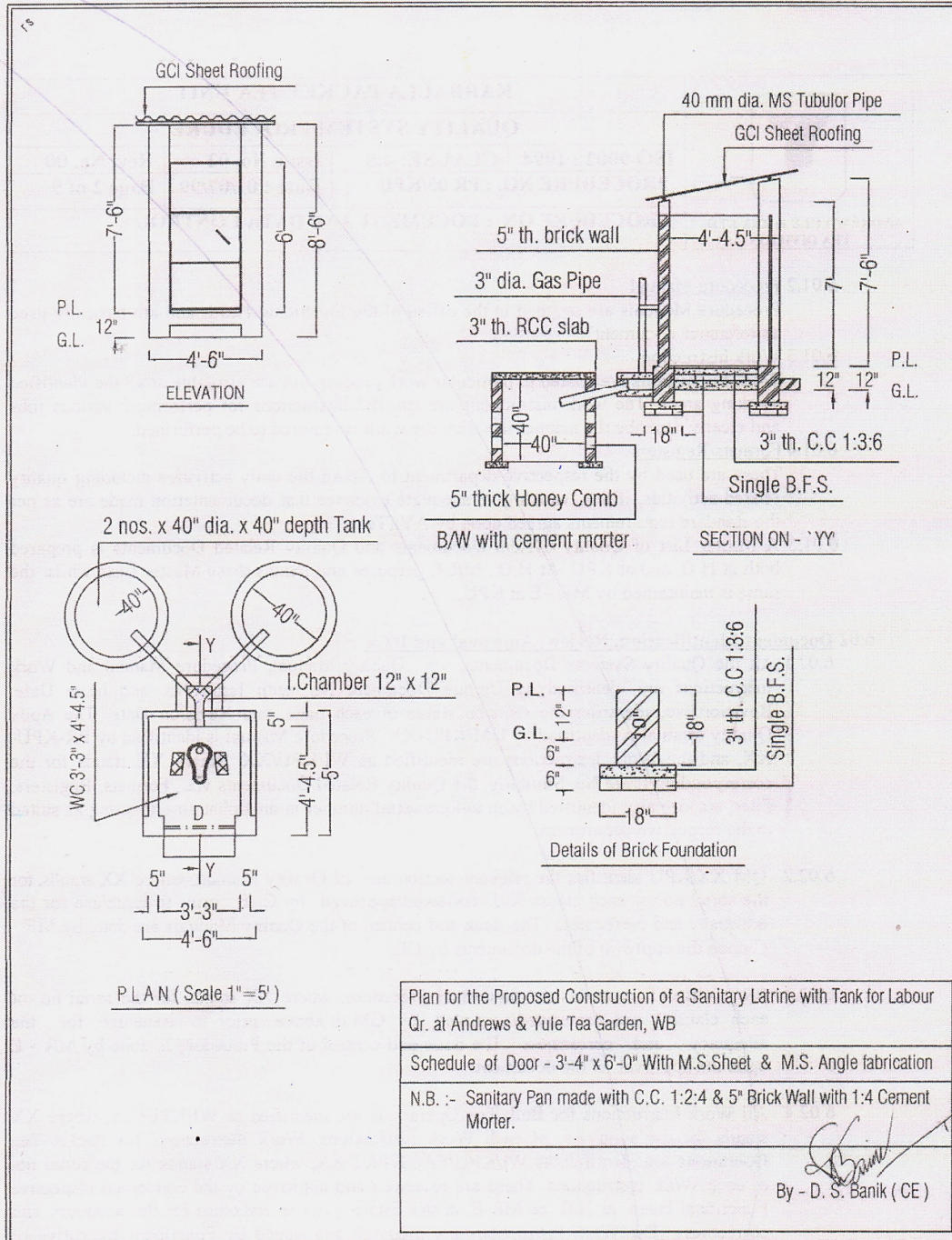

Plan for the Proposed Construction of a Sanitary Latrine with Tank for Labour Qr. at Andrews & Yule Tea Garden, WB

Schedule of Door - 3'-4" x 6'-0" With M.S. Sheet & M.S. Angle fabrication

N.B. :- Sanitary Pan made with C.C. 1:2:4 & 5" Brick Wall with 1:4 Cement Mortar.

By - D. S. Banik (CE)

Terms & Conditions:-

1. The quotation must include packing and delivery charges at the garden and no collection of stores will be made from your godown unless specifically agreed to.
2. All alterations in the quotations must be attested by full signature.
3. All quotation will be valid for 12 (twelve) months.
4. Rates are to be inclusive of all applicable taxes/ GST .
5. Actual need order quantity may vary from the indicated quantity at the sole discretion of Garden Management.
6. Job to be completed within 120 days from the date of receiving the formal order.
7. The specification cannot be changed. A tenderer who is unable to supply the material or work as per specification may however give Quotations for alternative items but this must be done on a separate sheet of paper or letter head of the firm with the words “ see item.....in the enclosed sheet” in this form.
8. In the event of failure to make supply or correct supply within the stipulated period, the garden will be in a liberty to make purchase elsewhere and the tenderer shall be liable to make good any loss suffered by the garden as a result of such purchases and failure to complete the job.
9. Taxes will be deducted as per statute.
10. Payment Terms: No advance payment. Part payment will be made on submission of bills, subject to 10% Retention money at each stage. Retention money will be released after one year of completion of job, if no dispute arises regarding quality, workmanship & delay in delivery/completion of the project.
11. Replacement of the defective/substandard material/job has to be made good within ..7.. days.
12. No price variation will be allowed other than natural calamity, fire etc subject to approval of the authority.
13. Management reserves the right of pre- delivery inspection.
14. Management reserves the right to split the order wherever found necessary with majority jobs to be reserved for L-1.
15. Management reserves the right to reject any or all quotations without assigning any reason whatsoever.
16. All supplies are deemed to be FOR garden, unless otherwise specially stated by you & subject to future approval by the authority in that case.
17. Quotation should be submitted according to the mentioned items as per our formal letter otherwise your quotation will be rejected.
18. L/D clause / Penalty clause shall be applicable if the job is not completed within the stipulated time mentioned in the purchase order, @ 0.5% of the total value for each week of delay from schedule date, subject to maximum 5% of total value unless there is a valid reason for such delay which will be scrutinized by the management. Management’s decision will be final & binding.
19. All the applicable labour laws relating to deployment of the labour/ employees will be strictly followed in executing the contracts and copy of your license relating to the job must be attached along with the quotation.
20. Force Majeure Clause: Any delays or failure of performance of either party here to will not constitute default there under or give rise to any claim for damage if any, to the extent such delays or failure of performance is caused by the concurrence such as act of god, or the public enemy, appropriation or confiscation of facilities by Govt. Authorities, act of war, rebellion or sabotage, fire, explosion, riots or illegal strike.
21. All disputes are subject to Jalpaiguri Jurisdiction only.